

# ATTENTION PRODUCTION!

## IMPORTANT INFORMATION

### DO NOT CHANGE OUR LAYOUT FOR ANY REASON.

Please allow 1/8" for any bleeds (see sample diagrams below).

Printed stock must be the same as the furnished layout/s.  
If we have to trim or jog your stock before die cutting, you will be notified in advance and charged accordingly.

Stock must be delivered flat, well jogged, protected, and face up.

The number of sheets should be clearly marked on the skid.

### SPOTTER MARKS:

Spotter marks are essential for die cutting in the proper position.

We suggest you run the first 2% of your printed stock with spotter marks and then remove them for the balance of the run.

Keep the spotter sheets separate, clearly marked, and at the top of the load.

Provide a rule-up, blueline, or sample for position.

Please call with any questions.

1/16" - 1/8" WHITE WRAP  
TO BACK ON SOLID  
COLOR FLAPS

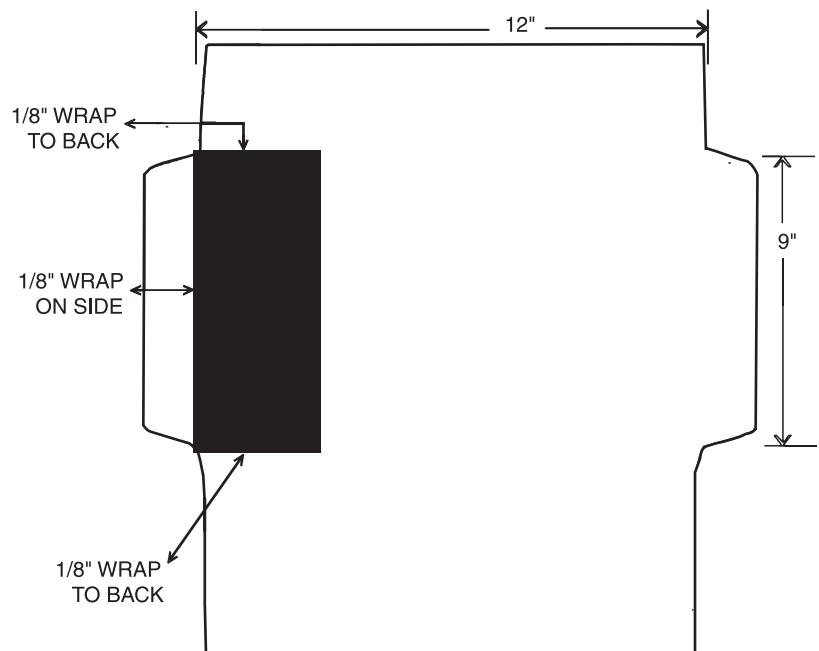

Thank you for your cooperation

L.A. ENVELOPE CO, INC.  
Ph: (323)838-9300  
Fax: (323)838-6120

Die Number	115	
Press Sheet	17-1/2 x 11-1/2	
Envelope Size	No. 10 4-1/8 x 9-1/2	
Type / Style	Open Side / Booklet	
Flap Length	2" Square Flap	
Cut Out	1	
Color Bar	Size:	Pos: Gripper
Gripper Size		
Comments: Full Bleed		
L.A. Envelope, Inc. 323 .838 .9300		

FACE

NO INK AREA

NO INK AREA

NO INK AREA

2"

4-1/8"

9-1/2"

SHEET SIZE

SHEET SIZE

GRAIN DIRECTION

GUIDE

GRIPPER

Bob 06/17/05